



晶采光電科技股份有限公司
AMPIRE CO., LTD.

SPECIFICATIONS FOR LCD MODULE

CUSTOMER	
CUSTOMER PART NO.	
AMPIRE PART NO.	AM-1024768Q6TZQW-00H
APPROVED BY	
DATE	

- Preliminary Specification
 Formal Specification

AMPIRE CO., LTD.

**4F., No.116, Sec. 1, Xintai 5th Rd., Xizhi Dist., New Taipei
City221, Taiwan (R.O.C.)**

新北市汐止區新台五路一段 116 號 4 樓(東方科學園區 A 棟)

TEL:886-2-26967269 , FAX:886-2-26967196 or 26967270

Approved by	Checked by	Organized by
Patrick	Jessica	Simon

This Specification is subject to change without notice.

RECORD OF REVISION

Revision Date	Page	Contents	Editor
2022/07/14	-	New Release	Simon
2023/04/06	15	Update Interface Description	Tank

1. FEATURES

The TFT is a Color Active Matrix Liquid Crystal Display with a back light system. The matrix uses a-Si Thin Film Transistor as a switching device. This TFT LCD has a 15 inch diagonally measured active display area with XGA resolution (1,024 horizontal by 768 vertical pixels array)..

- (1) 15.0 inch configuration
- (2) One channel LVDS interface
- (3) 16.2M color by 8 bit R.G.B signal input
- (4) RoHS Compliance

2. PHYSICAL SPECIFICATIONS

Item	Specifications	Unit	Note
LCD size	15.0" (Diagonal)	inch	
Active area	304.13 (H) ×228.10 (V)	mm	
Number of pixels	1024(H) ×768(V)	pixels	
Pixel pitch	0.297(H) × 0.297(V)	mm	
Pixel arrangement	RGB Vertical stripe		
Display colors	16.2M	colors	
Display mode	Normally Black		
Dimensional outline	326.5 (Typ) ×253.5 (Typ) ×12.50(D)	mm	
Back-light	Single LED (Side-Light type)		
Surface Treatment	AG+3H		

3. ABSOLUTE MAX. RATINGS

Item	Symbol	Values		UNIT	Note
		Min.	Max.		
Logic Supply Voltage	V _{DD}	-0.3	3.6	V	(1)(2)(3)(4)
Operating Temperature	T _{OPA}	-20	70	°C	
Storage Temperature	T _{STG}	-30	80	°C	

Note (1) All the parameters specified in the table are absolute maximum rating values that may cause faulty operation or unrecoverable damage, if exceeded. It is recommended to follow the typical value.

Note (2) All the contents of electro-optical specifications and display fineness are guaranteed under Normal Conditions. All the display fineness should be inspected under normal conditions. Normal conditions are defined as follow: Temperature: 25°C, Humidity: 55± 10%RH.

Note (3) Unpredictable results may occur when it was used in extreme conditions. T_a= Ambient Temperature, T_{gs}= Glass Surface Temperature. All the display fineness should be inspected under normal conditions.

Note (4) Temperature and relative humidity range are shown in the figure below. Wet bulb temperature should be lower than 47°C, and no condensation of water. Besides, protect the module from static electricity

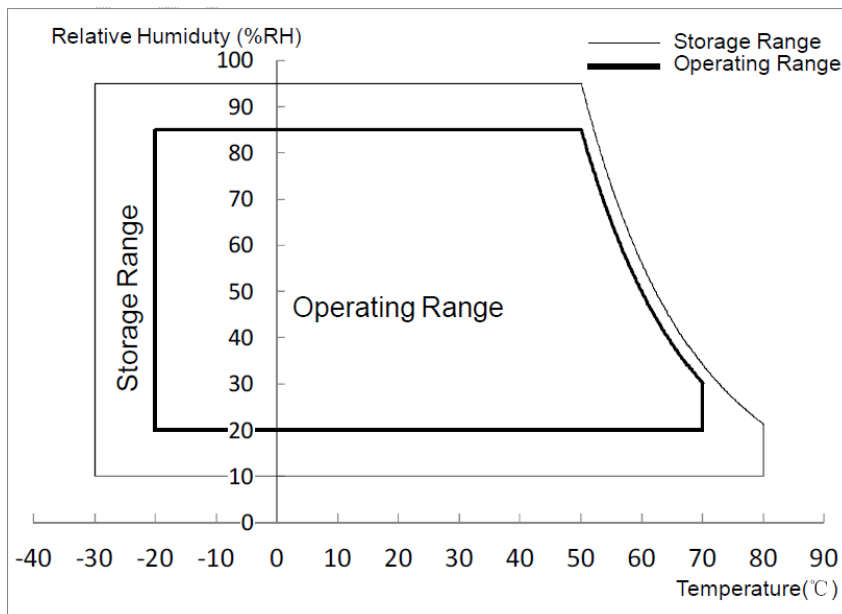

Figure 3 Absolute Ratings of Environment of the LCD Module

4. ELECTRICAL CHARACTERISTICS

4.1 Signal Electrical Characteristics

4.2.1 Signal Electrical Characteristics For LVDS Receiver

The built-in LVDS receiver is compatible with (ANSI/TIA/TIA-644) standard.

Table 7 LVDS Receiver Electrical Characteristics

Item	Symbol	Min.	Typ.	Max.	UNIT	Note
Differential Input High Threshold	V _{th}	-	-	(+150)	mV	V _{CM} =1.2V
Differential Input Low Threshold	V _{tl}	(-150)	-	-	mV	V _{CM} =1.2V
Magnitude Differential Input Voltage	V _{ID}	(150)	-	(600)	mV	
Common Mode Voltage	V _{CM}	-	(1.2)	-	V	
Input Leakage Current	/	(-10)	-	(10)	uA	

Note (1) Input signals shall be low or Hi- resistance state when VCC is off.

Note (2) All electrical characteristics for LVDS signal are defined and shall be measured at the interface connector of LCD.

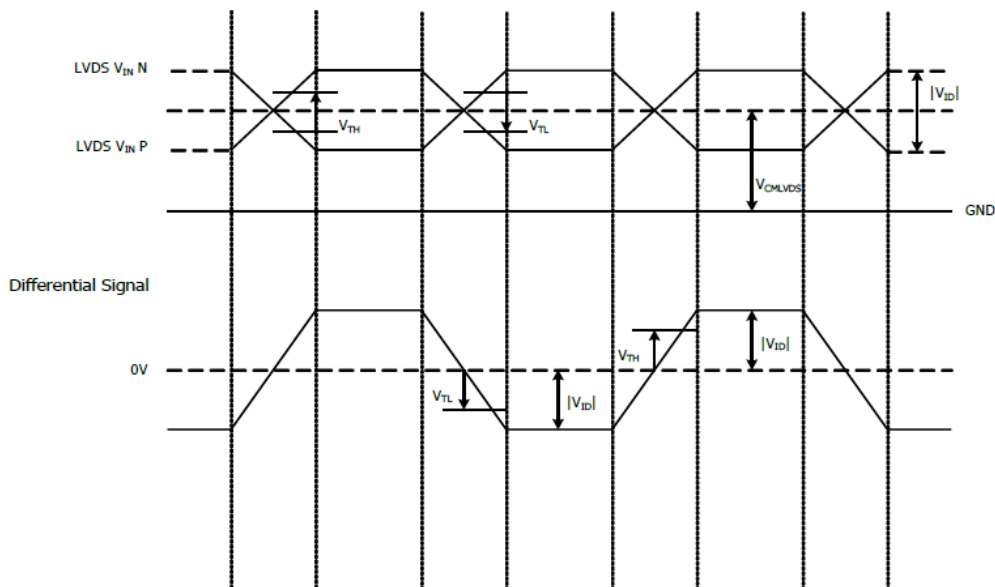

Figure 8 Voltage Definitions

Table 8 LVDS AC Electrical Characteristics

Parameter	Symbol	Min.	Typ.	Max.	Unit
Clock Period	TLVCP	-	(T)	-	ns
Clock High Time	TLVCH	-	(4T/7)	-	ns
Clock Low Time	TLVCL	-	(3T/7)	-	ns

Note : T=1/Fclk

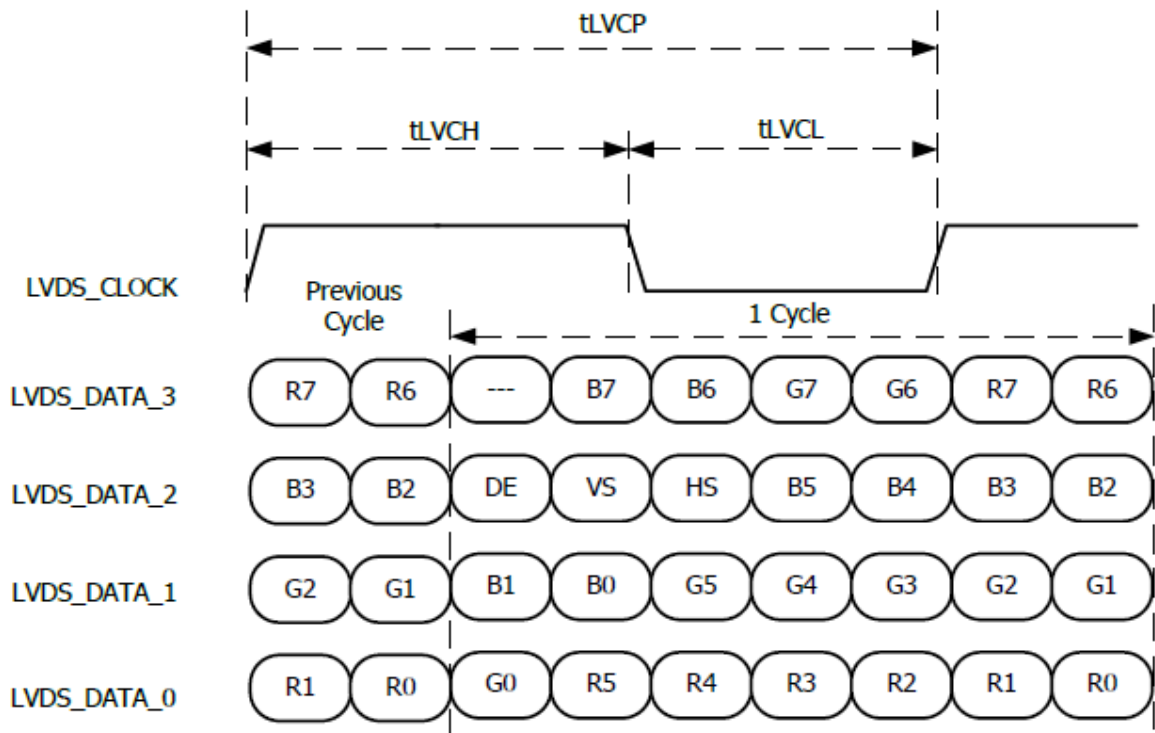

Figure 9 Data Mapping

4.2.2 LVDS Receiver Internal Circuit

Figure 11 shows the internal block diagram of the LVDS receiver. This LCD module equips termination resistors for LVDS link.

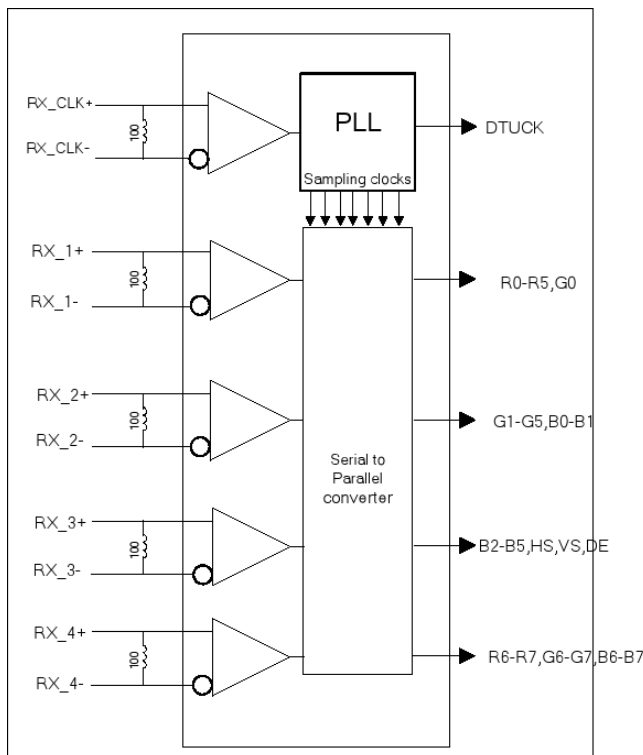

Figure 10 LVDS Receiver Internal Circuit

4.3 Interface Timings

Table 9 Interface Timings

Parameter	Symbol	Min.	Typ.	Max.	Unit
LVDS Clock Frequency	Fclk	(50)	(65)	(80)	MHz
H Total Time	HT	(1224)	(1,344)	(1720)	Clocks
H Active Time	HA	1,024			
V Total Time	VT	(783)	(806)	(968)	Lines
V Active Time	VA	768			
Frame Rate	FV	(55)	(60)	(65)	Hz

Note (1) Synchronization Method: DE only

Note (2) H Blank area and V Blank area can not be changed at every frame.

4.4 Backlight Driving Conditions

Table 3 Parameter Guideline for LED Backlight

Parameter	Symbol	Min.	Typ.	Max.	Unit	Note	
System Power Supply							
LCD Drive Voltage (Logic)	V_{CC}	(3.0)	(3.3)	(3.6)	V	(1), (2)	
VCC Current	Black Pattern	I_{CC}	-	-	(0.394)	A	(1),(2),(3)
VCC Power Consumption	Black Pattern	P_{CC}	-	-	(1.3)	W	
Rush Current		I_{Rush}	-	-	(1.5)	A	(1), (4)
Allowable Logic/LCD Drive Ripple Voltage		V_{VCC-RP}	-	-	(200)	mV	(1)
LED Power Supply							
LED Input Voltage		V_{LED}	(10.8)	(12)	(12.6)	V	(1),(2)
LED Power Consumption		P_{LED}	-	-	(12.8)	W	(1),(5)
PWM Signal Voltage	High	V_{PWM}	(2.5)	(3.3)	(3.6)	V	(1),(2)
	Low		-	-	(0.5)		
LED Enable Voltage	High	V_{LED_EN}	(2.5)	(3.3)	(3.6)	V	
	Low		-	-	(0.5)		
Input PWM Frequency		F_{PWM}	(200)	-	(20K)	Hz	(1),(6),(7) Ddim ≥ 5%
LED Life Time		LT	30,000	50,000	-	Hours	(1),(8)

Note (1) All of the specifications are guaranteed under normal conditions. Normal conditions are defined as follow: Temperature: 25°C, Humidity: 55± 10%RH.

Note (2) All of the absolute maximum ratings specified in the table, if exceeded, may cause faulty operation or unrecoverable damage. It is recommended to follow the typical value.

Note (3) The specified V_{CC} current and power consumption are measured under the $V_{CC} = 3.3$ V, $F_v = 60$ Hz condition and Black Pattern.

Note (4) The figures below is the measuring condition of V_{CC} . Rush current can be measured when T_{RUSH} is 0.5 ms.

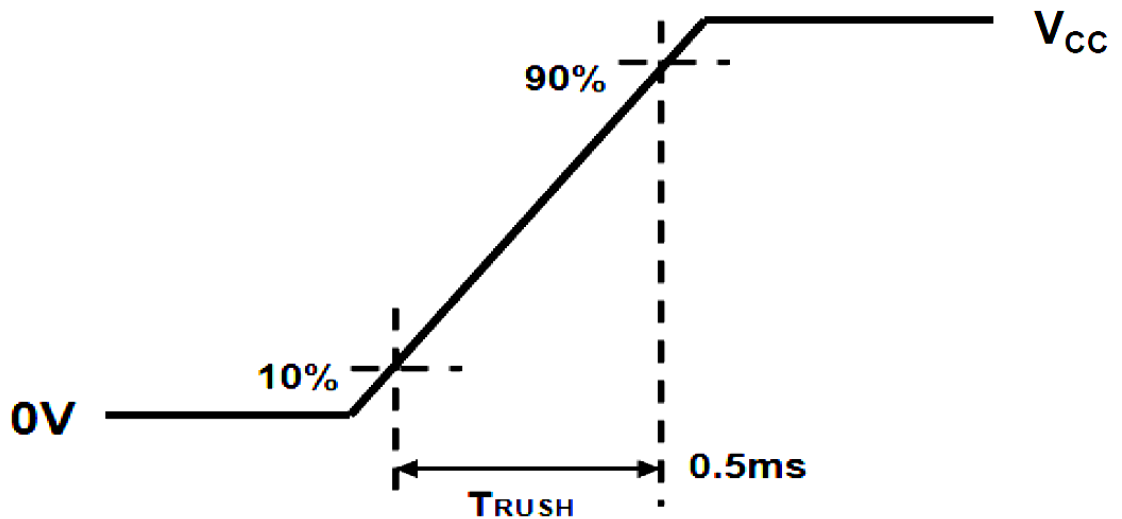

Figure 11 V_{CC} Rising Time

Note (5) The power consumption of LED Driver are under the $V_{LED} = 12.0V$, Dimming of Max luminance.

Note (6) Although acceptable range as defined, the dimming ratio is not effective at all conditions. The PWM frequency should be fixed and stable for more consistent luminance control at any specific level desired.

Note (7) The operation of LED Driver below minimum dimming ratio may cause flickering or reliability issue.

Note (8) The life time is determined as the sum of the lighting time till the luminance of LCD at the typical LED current reducing to 50% of the minimum value under normal operating condition.

4.5 Power ON/OFF Sequence

Interface signals are also shown in the chart. Signals from any system shall be Hi- resistance state or low level when Vcc voltage is off.

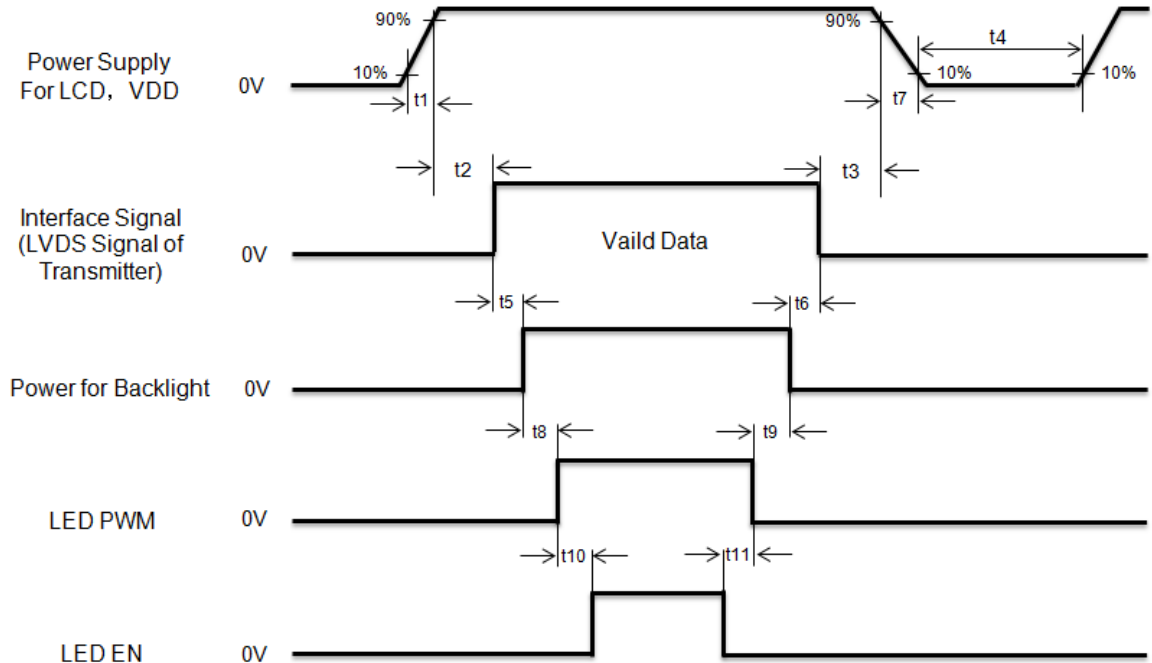

Figure 12 Power Sequence

Table 11 Power Sequencing Requirements

Parameter	Symbol	Min.	Typ.	Max.	Unit
VCC Rise Time	T1	(0.5)	-	(10)	ms
VCC Good to Signal Valid	T2	(0)	-	(50)	ms
Signal Disable to Power Down	T3	(0)	-	(1,000)	ms
Power Off	T4	(1,000)	-	-	ms
Signal Valid to VLED On	T5	(300)	-	-	ms
VLED Off to Signal Disable	T6	(200)	-	-	ms
VCC Fall Time	T7	(0.5)	-	(10)	ms
VLED On to LED PWM On	T8	(10)	-	-	ms
LED PWM Off to VLED Off	T9	(10)	-	-	ms
LED PWM On LED EN On	T10	(10)	-	-	ms
LED EN Off to LED PWM Off	T11	(10)	-	-	ms

5. OPTICAL SPECIFICATION

5.1 Optical specification

Item	Symbol	Condition	Values			Unit	Note
			Min.	Typ.	Max.		
Viewing angle	θL	$(CR \geq 10)$	80	85	--	degree	(1)(2)(3)(4)(8)
	θR		80	85	--		
	θU		80	85	--		
	θD		80	85	--		
Response time	T_{F+TR}	Normal $\theta = \Phi = 0^\circ$	--	--	25	msec	(1)(2)(5)(8)
						msec	
Contrast ratio	CR		450	800	--	--	(1)(2)(4)(8)
Color chromaticity	WX		0.263	0.313	0.363	--	(1)(2)(3)(8)
	WY		0.279	0.329	0.379	--	
	RX		0.586	0.636	0.686	--	
	RY		0.296	0.346	0.396	--	
	GX		0.272	0.322	0.372	--	
	GY		0.572	0.622	0.672	--	
	BX		0.103	0.153	0.203	--	
	BY	0.013	0.063	0.113	--		
Luminance	L	340	400	--	cd/m ²	Note4	
Luminance uniformity	YU	75	80	--	%	Note5	

Note (1) Measurement Setup:

The LCD module should be stabilized at given temperature(25°C) for 30 minutes to avoid abrupt temperature changing during measuring. In order to stabilize the luminance, the measurement should be executed after lighting backlight for 30 minutes in a windless room.

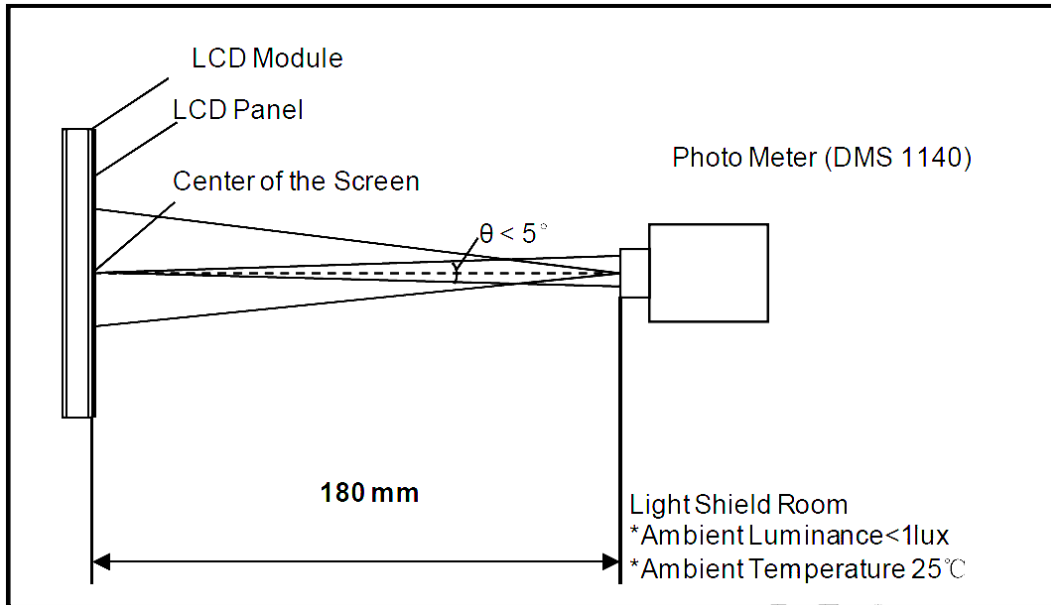

Figure 4 Measurement Setup

Note (2) The LED input parameter setting as:

VLED: 12V

PWM_LED: Duty 100 %

Note (3) Definition of Viewing Angle

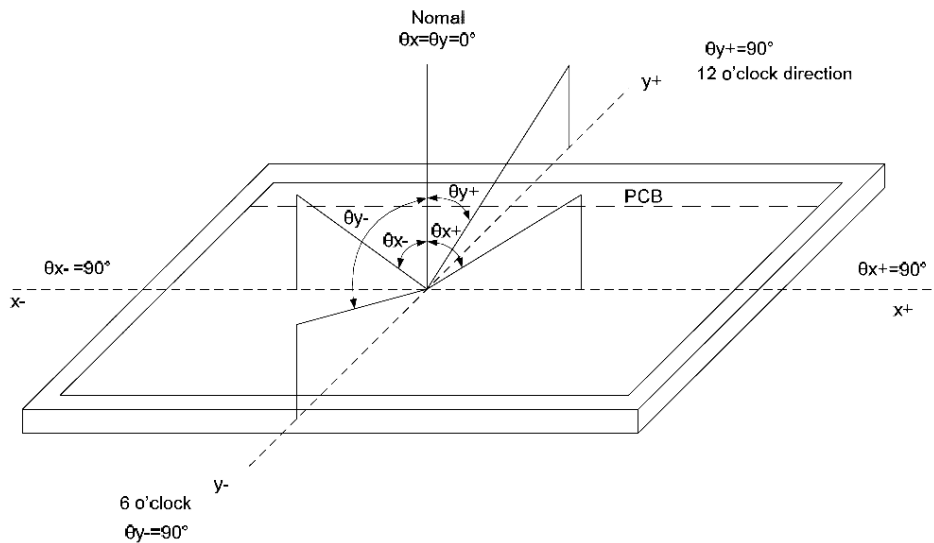

Figure 5 Definition of Viewing Angle

Note (4) Definition of Contrast Ratio (CR)

The contrast ratio can be calculated by the following expression:

Contrast Ratio (CR) = The luminance of White pattern/ The luminance of Black pattern

Note (5) Definition of Response Time (T_R , T_F)

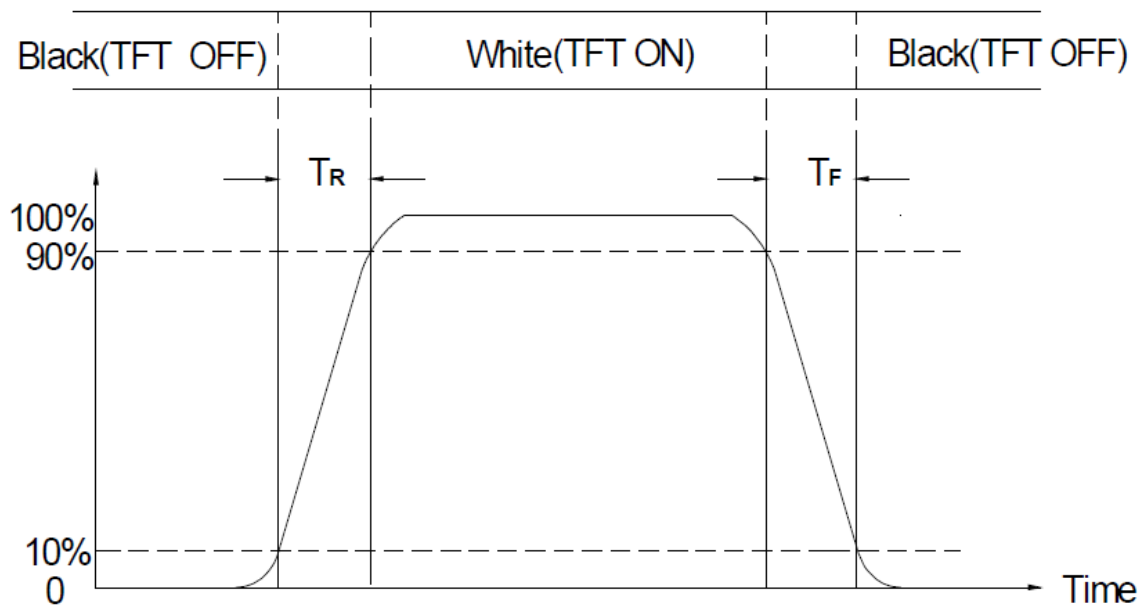

Figure 6 Definition of Response Time

Note (6) Definition of Luminance of White

Measure the luminance of White pattern (Ref.: Active Area)

Display Luminance= L_1 (center point)

H—Active Area Width, V—Active Area Height, L—Luminance

Note (7) Definition of Luminance Uniformity (Ref.: Active Area)

Measure the luminance of White pattern at 9 points.

Luminance Uniformity= $\text{Min.}(L_1, L_2, \dots, L_X) / \text{Max.}(L_1, L_2, \dots, L_X)$

H—Active Area Width, V—Active Area Height, L—Luminance

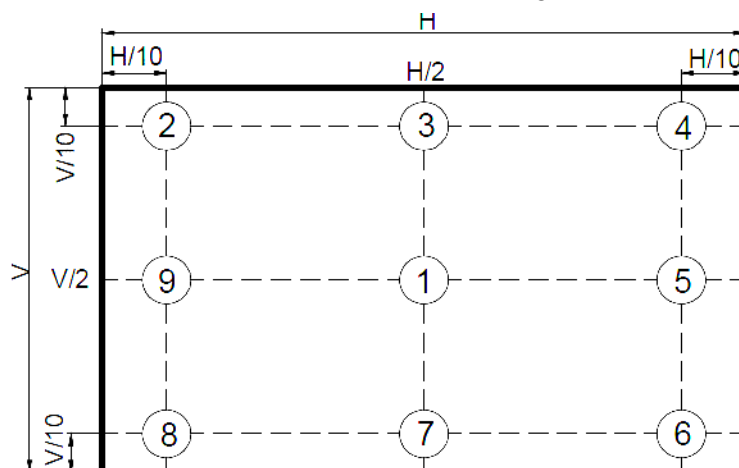
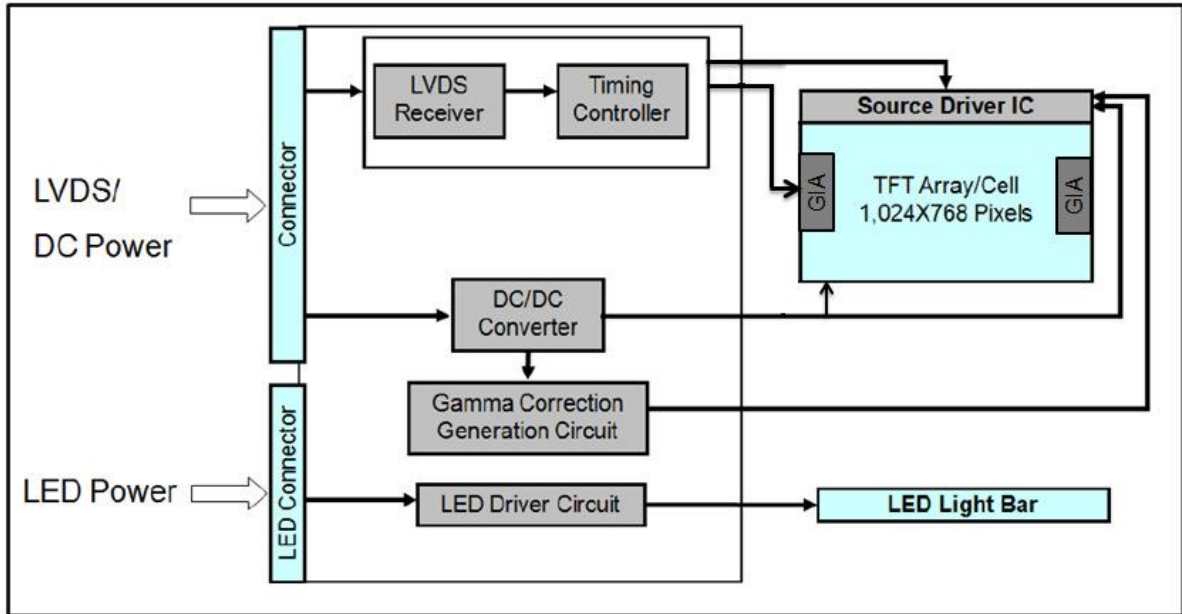

Figure 7 Measurement Locations of 9 Points

Note (8) All optical data are based on IVO given system & nominal parameter & testing machine in this document.

6. BLOCK DIAGRAM

6.1 TFTLCD Module



6.2 Pixel format

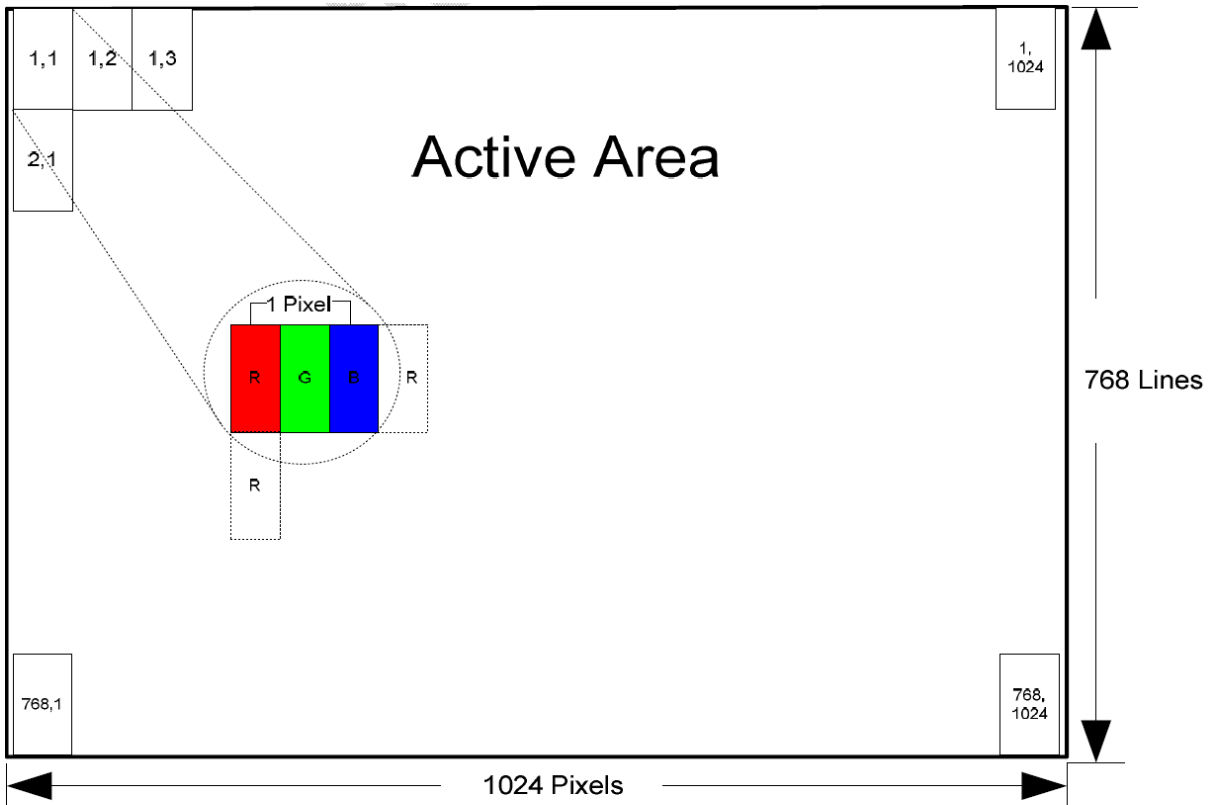

Figure 2 Pixel Mapping

7.INTERFACE

7.1 Electrical Interface Connection

CN1(Input signal): MSB240420HD

Pin No.	Symbol	Description	Note
1	VDD	3.3V Power	
2	VDD	3.3V Power	
3	SDA	Please Keep NC in the Customer	Note1*
4	SCL	Please Keep NC in the Customer	Note1*
5	Rin1-	LVDS Data Signal - Rin1-	
6	Rin1+	LVDS Data Signal+ Rin1+	
7	VSS	Ground	
8	Rin2-	LVDS Data Signal – Rin2-	
9	Rin2+	LVDS Data Signal+ Rin2+	
10	VSS	Ground	
11	Rin3-	LVDS Data Signal – Rin3-	
12	Rin3+	LVDS Data Signal+ Rin3+	
13	VSS	Ground	
14	CIKIN-	LVDS Clock Signal - CIKIN-	
15	CIKIN+	LVDS Clock Signal+ CIKIN+	
16	GND	Ground	
17	Rin4-	LVDS Data Signal – Rin4-	
18	Rin4+	LVDS Data Signal+ Rin4+	
19	VSS	Ground	
20	BIST	LCD Panel Self-Test Enable(3.3V Typ.), When it is not used, please connect to GND.	

LED Interface Connector

Table 6 Connector Name / Designation

Connector Name/Designation	LED Driver Connector
Manufacturer	STM or compatible
Connector Model Number	MSB24038P5A or compatible
Mating Model Number	P24038P5A or compatible

Table 7 LED Connector Pin Assignment

Pin#	Symbol	Signal Name
1	Vcc	12V
2	GND	GND
3	Enable	5V-On / 0V-Off
4	Dimming	PWM Dimming or Analog Dimming
5	NC	NC

9. RELIABILITY TEST CONDITIONS

Test Item	Test Conditions	Note
High Temperature Operation	70±3°C , Dry t=240 hrs	
Low Temperature Operation	-20±3°C , Dry t=240 hrs	
High Temperature Storage	80±3°C , Dry t=240 hrs	1,2
Low Temperature Storage	-30±3°C , Dry t=240 hrs	1,2
Storage at High Temperature and Humidity	50°C, 85% RH , 240 hrs	1,2
Thermal Shock Test	-20°C (30min) ~ 70°C (30min) 100 cycles	1,2
Vibration Test (Packing)	Sweep frequency : 10 ~ 55 ~ 10 Hz/1min Amplitude : 0.75mm Test direction : X.Y.Z/3 axis Duration : 30min/each axis	2

Note 1 : Condensation of water is not permitted on the module.

Note 2 : The module should be inspected after 1 hour storage in normal conditions (15-35°C , 45-65%RH).

10. HANDLING & CAUTIONS

10.1 Cautions when taking out the module

Pick the pouch only, when taking out module from a shipping package.

10.2 Cautions for handling the module

10.2.1 As the electrostatic discharges may break the LCD module, handle the LCD module with care. Peel a protection sheet off from the LCD panel surface as slowly as possible.

10.2.2 As the LCD panel and backlight element are made from fragile glass material, impulse and pressure to the LCD module should be avoided.

10.2.3 As the surface of the polarizer is very soft and easily scratched, use a soft dry cloth without chemicals for cleaning.

10.2.4 Do not pull the interface connector in or out while the LCD module is operating.

10.2.5 Put the module display side down on a flat horizontal plane.

10.2.6 Handle connectors and cables with care.

10.3 Cautions for the operation

10.3.1 When the module is operating, do not lose MCLK, DE signals. If any one of these signals were lost, the LCD panel would be damaged.

10.3.2 Obey the supply voltage sequence. If wrong sequence were applied, the module would be damaged.

10.4 Cautions for the atmosphere

10.4.1 Dewdrop atmosphere should be avoided.

10.4.2 Do not store and/or operate the LCD module in a high temperature and/or humidity atmosphere. Storage in an electro-conductive polymer-packing pouch and under relatively low temperature atmosphere is recommended.

10.5 Cautions for the module characteristics

10.5.1 Do not apply fixed pattern data signal to the LCD module at product aging.

10.5.2 Applying fixed pattern for a long time may cause image sticking.

10.6 Other cautions

10.6.1 Do not disassemble and/or re-assemble LCD module.

10.6.2 Do not re-adjust variable resistor or switch etc.

10.6.3 When returning the module for repair or etc, please pack the module not to be broken. We recommend using the original shipping packages.

10.6.4 AMIPRE will provide one year warrantee for all products and three months warrantee for all repairing products.

10.6.5 Do not keep the LCD at the same display pattern continually. The residual image will happen and it will damage the LCD. Please use screen saver.

11. OUTLINE DIMENSION

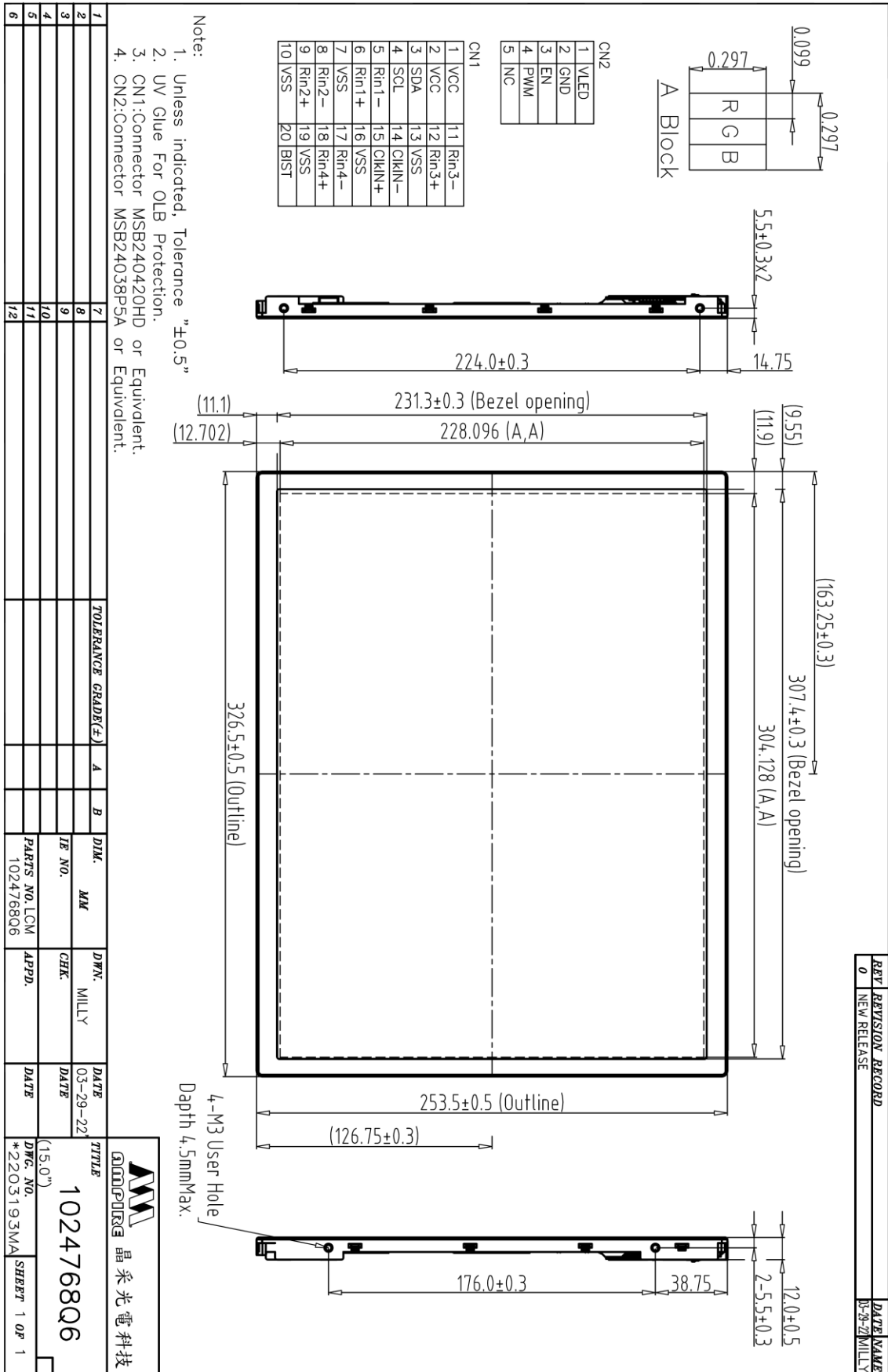

REV	REVISION RECORD	DATE	NAME
0	NEW RELEASE	05-29-22	MILLY

晶采光電科技	
TITLE	1024768Q6
DWG. NO.	(15.07) *2203193MA
SHEET	1 OF 1

REV	REVISION RECORD	DATE	NAME
0	NEW RELEASE	03-29-22	MILLY

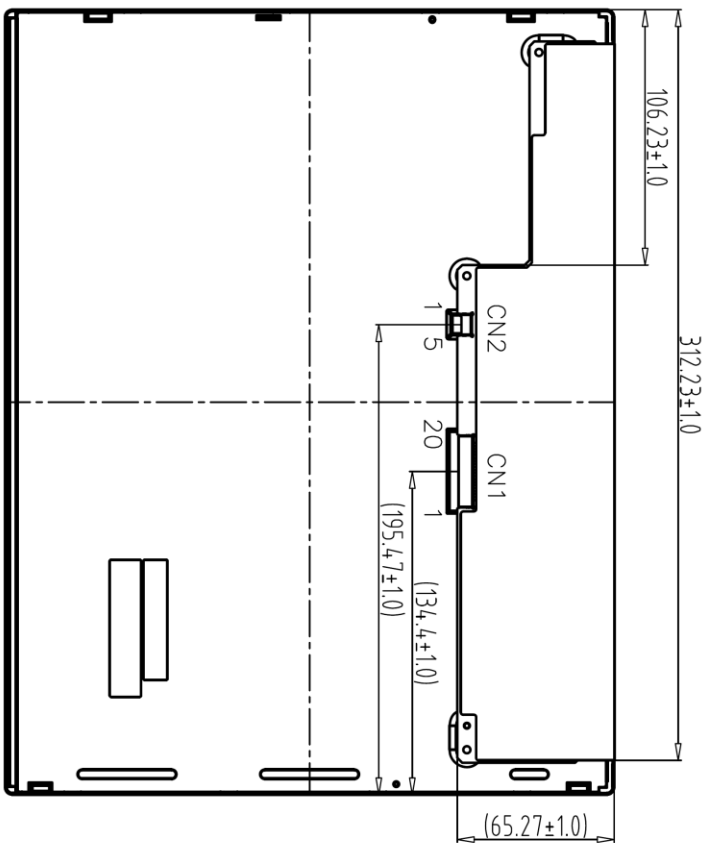

CN2

1	VLED
2	GND
3	EN
4	PWM
5	NC

CN1

1	VCC	11	Rin3-
2	VCC	12	Rin3+
3	SDA	13	VSS
4	SCL	14	CIKIN-
5	Rin1-	15	CIKIN+
6	Rin1+	16	VSS
7	VSS	17	Rin4-
8	Rin2-	18	Rin4+
9	Rin2+	19	VSS
10	VSS	20	BIST

- Note:
1. Unless indicated, Tolerance "±0.5"
 2. UV Glue For OLB Protection.
 3. CN1:Connector MSB240420HD or Equivalent.
 4. CN2:Connector MSB24038PSA or Equivalent.

Back view

1		7		TOLERANCE GRADE(±)	A	B	DRW. MILLY	DATE	03-29-22
2		8					CHK.	DATE	
3		9						DATE	
4		10						DATE	
5		11						DATE	
6		12						DATE	

MM	MM	DRW. MILLY	DATE

PARTS NO.	102476806
DRG. NO.	**2203194MA
SHEET	1 OF 1